



OT-8000 SERVICE MANUAL

ScubaMax

→ Regulator Service Manual →



Professional SCUBA Diving Equipment

SCUBA MAX

→ Tel: (909) 869-7977 Fax: (909) 595-8600

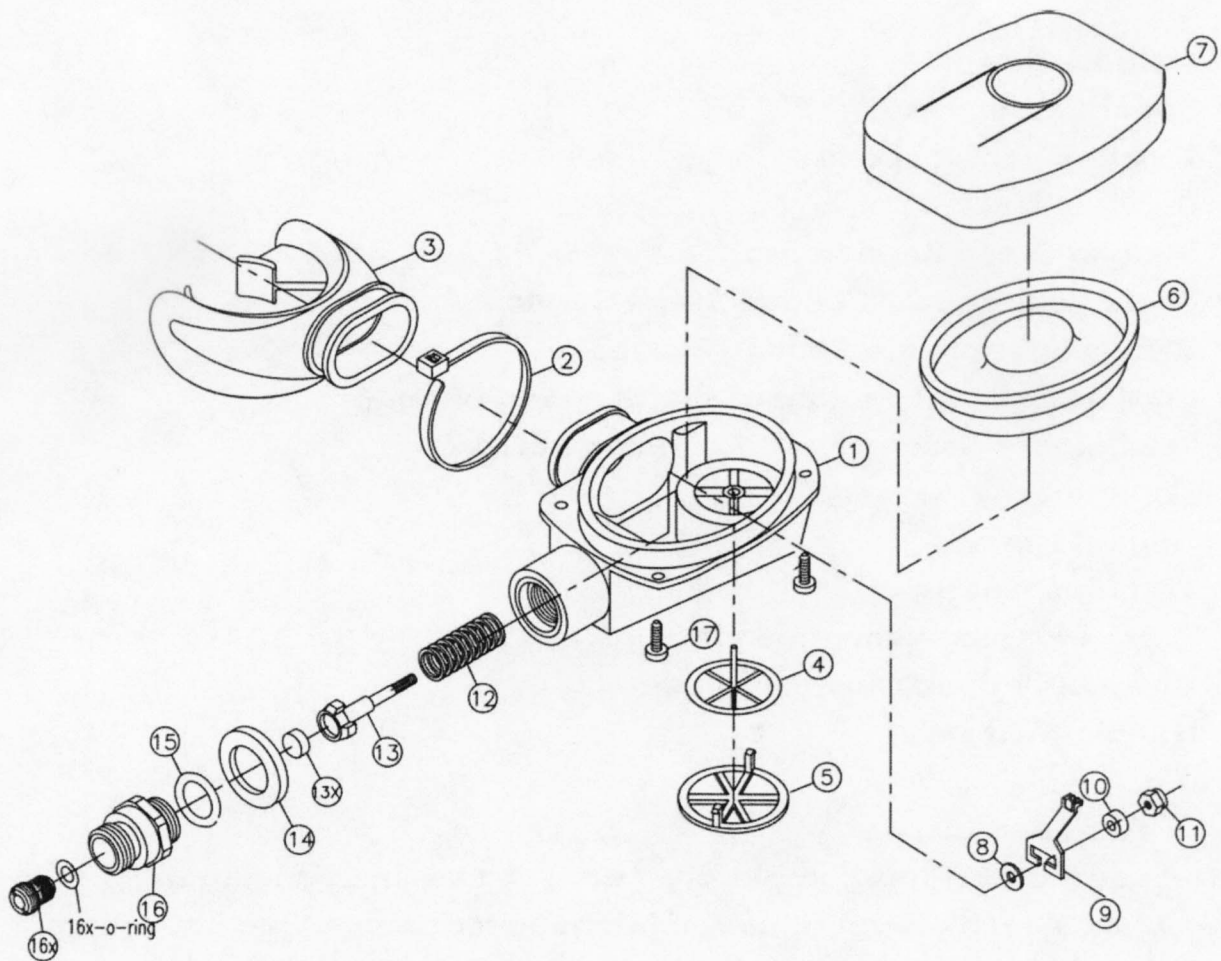

ITEM	PART NO	DESCRIPTON	ITEM	PART NO	DESCRIPTON
1	9501	MAIN HOUSING	11	9511	STAINLESS NYLON NUT
2	9502	NYLON TIE	12	9512	MAIN SPRING
3	9503	SILICONE MOUTHPIECE	13	9513	POPPET
4	9504	SILICONE VALVE	13X	9513-X	LP SEAT
5	9505	EXHAUSE COVER	14	9514	BRASS RING
6	9506	DIAPHRAGM	15	9515	O-RING
7	9507	FRONT COVER	16	9516	INLET NIPPLE
8	9508	SPACER	16X	9516X	ORIFICE
9	9509	LEVER ARM	16X-O	9516X-O	ORIFICE-O-RING
10	9510	SPACER	17	9517	SCREW

TABLE OF CONTENTS

- 1.0 Introduction
- 2.0 Specifications
 - 2.1 Torque Specifications
- 3.0 Service Kit List
- 4.0 Second Stage Service Procedures
 - 4.1 Tools Required for Second Stage Servicing
 - 4.2 Disassembly of the Second Stage
 - 4.3 Cleaning and Inspection of the Second Stage
 - 4.4 Preliminary Assembly of the Second Stage
 - 4.5 Set-up of the Second Stage
- 5.0 Helpful Hints
 - 5.1 Troubleshooting
 - 5.2 Parts Cleaning Recommendations
 - 5.3 Commonly Used Cleaning Solutions
 - 5.4 Handling Tips

Before You Begin

Read these instructions completely before you begin servicing the regulator or filling whip. These instructions are intended for people who have been **AUTHORIZED** by **SCUBAMAX** to repair **SCUBAMAX** Scuba equipment. If you are not so authorized - **STOP**.

1.0 INTRODUCTION

- 1.0.1 The procedures in this manual apply to the **SCUBAMAX** the **OT-8000** type 2ND stage. Refer to the exploded views as you read the service section of the manual. The Item Numbers referred to in the service section are those seen in the corresponding exploded view



! WARNING !

NEVER tighten the hose fitting to the first stage with more than 40 in. lbs. (4.5 Nm) of torque. The inlet hose fitting will be weakened by over tightening. Failure to heed this warning may result in serious injury or death.

NOTE:

All **SCUBAMAX** Scuba Regulators have service kits available which contain the parts which must be changed at every annual service no matter what their condition. The standard annual service kit part numbers are shown in the parts list. All other parts not contained in these kits must be inspected by the technician and changed if necessary. Parts will be handled under warranty, only if they have failed due to problems with material or workmanship.

**! WARNING !**

SCUBAMAX Scuba Regulators are manufactured using materials suitable for use with oxygen enriched gases (i.e. Nitrox, etc.) providing the oxygen content does not exceed 40%. Equipment intended for enriched air (Nitrox) use, must not be used with regular compressed breathing air or other gases. Regulators intended for enriched air use, can be serviced only by technicians trained by one of the major oxygen enriched air training agencies. Failure to heed this warning may result in serious injury or death.

- 1.0.2** This manual gives breakdowns of regulator parts, equipment specifications, servicing instructions, troubleshooting recommendations, and guidelines for proper care of **SCUBAMAX** regulators. This manual is intended for use only by persons specially trained and authorized to service **SCUBAMAX** Scuba equipment.
- 1.0.3** Anyone attempting to service or repair **SCUBAMAX** Scuba regulators must have a thorough understanding of the principles of operation of scuba regulators and valves, as well as the appropriate mechanical ability. The technician must be properly trained in the safe use of compressed air and the various tools and cleaning solutions involved in the procedures outlined in this manual.
- 1.0.4** The best source for current part numbers for any of the parts listed in this manual is your current parts and price list from **SCUBAMAX**.
- 1.0.5** If you have any questions, or need more information, contact your

SCUBAMAX Scuba Sales Representative or SCUBAMAX Customer Service. You can e-mail you technical questions to SCUBAMAX'S mail box.

2.0 SPECIFICATIONS

PROBLUE OT-8000 SECOND STAGE REGULATOR

AIR FLOW 33 cu. ft. (935 liters/min). @ 1 atmosphere
INHALATION RESISTANCE .. 0.9" -2.0" (2.3 - 5.08 cm) w.c. @ 1 atmosphere
EXHALATION RESISTANCE .. 0.6" (1.52 cm) w.c. max. @ 1 atm.

RECOMMENDED LUBRICANT LTI Christo-Lube 111®



A. OT-8000 SECOND STAGE REGULATOR

TYPEPOPPET VALVE , BALANCE DIAPHRAGM
WEIGHT.....5 lb. (w/o hose)
MATERIALSCOVER ----- ABS
HOUSING ----- ABS HI-IMPACT
LP SEAT ---- SILICONE
O-RING ----- Buna-N
DIAPHRAGM ----- SILICONE
EXHAUST VALVE----- SILICONE
MOUTHPIECE ---- SILICONE

2.1 Torque Specifications:

Description	Item #	Torque
INLET NIPPLE	16	85-95 in/lbs (9.6-10.7 Nm)
SCREW	17	1-2 ft/lb (2-3 Nm)
Hose inlet end		2-3 ft/lb (3-4 Nm)
Hose outlet end		2-3 ft/lb (3-4 Nm)

3.0 SERVICE KIT LIST

DRAWING	NO	PART NO	DESCRIPTION	Q'TY
	13X	9513X	LP SEAT	1
	15	9515	O-RING	1
	16X-0	9516X-0	O-RING	1

3.1 SERVICE TOOL LIST

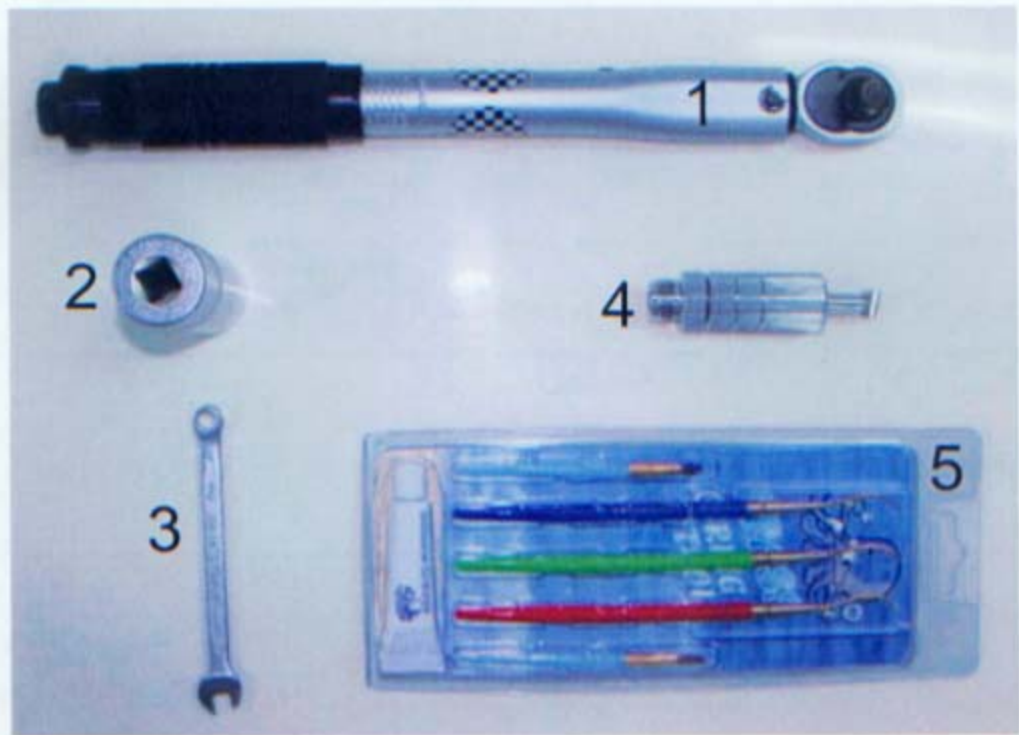

1	TORQUE WRENCH 5-25 N.M	2	19MM HEX SOCKET
3	6MM COMBINATION WRENCH	4	ADJUST TOOL
5	O-RING TOOL SET	6	4H POPPET TOOL
7	" + " SCREWDRIVER		

4.0 SERVICE PROCEDURES FOR THE SCUBAMAX OT-8000

- 4.0.1 Before you begin disassembly of the regulator, test the first and second stages for output pressures and leakage. Pre-testing in this way will help the technician to pinpoint any specific problems requiring repair.**
- 4.0.2 The work area must be clean and well lighted, with clean compressed air available to blow sand and dirt from parts.**
- 4.0.3 The procedures covered in this manual section apply to the OT-8000 second stage. To access the exploded view of this model open the front cover of this manual.**

4.1 TOOLS REQUIRED (or suggested) FOR SECOND STAGE SERVICING

- **19MM HEX DEEP SOCKET**
- **4H POPPET TOOL**
- **6MM COMBINATION WRENCH**
- **Adjust tool for second stage**
- **SPIDER SCREWDRIVER**
- **OT-8000 2nd Stage Annual Service Kit**
- **Clean Shop Rags**
- **Dow-Corning Compound 111**

Silicone Grease or LTI Christo-Lube 111[®] (p/n 347-0111)

4.2 DISASSEMBLY OF THE SECOND STAGE



! WARNING !

NEVER tighten the hose fitting to the first stage with more than 40 in. lbs. (4.5 Nm) of torque. The inlet hose fitting can be weakened by over tightening. To view the complete parts list of the second stage, open the front cover of this manual.

4.2.1

Use the 6" and 8" adjustable wrenches to loosen the hose nut from the INLET NIPPLE (16). Remove the hose assembly from the second stage. Inspect the hose assembly for any cuts or cracks, especially on the hose at the metal ferrules. Blow the interior bores of the hoses.

Replace the hose assembly if any cuts or cracks are found. Remove and discard the O-rings from each end of the hose. Clean, rinse, and blow-dry the interior bores of the hoses. Replace the hoses if necessary.

4.2.2

If the mouthpiece is in good condition, you can don't remove and be reused. If not good to remove the mouthpiece (3) by cutting the mouthpiece tie(2) with side cutting pliers. Discard the old mouthpiece tie. Examine the condition of the mouthpiece.

4.2.3

Remove the exhaust cover (5) from the case by pulling it back.

4.2.4

Before removing the exhaust valve (4) from the housing (1), bend the valve over as far as it will go from the top, bottom, left, and right sides. If it fails to snap back quickly, and does not lie perfectly flat against the housing exhaust grid, the valve should be replaced. If it does snap back satisfactorily, remove it by pulling it out with your fingers. Inspect the sealing edges. If they appear smooth, and the locking tab on the nipple

is good, the valve can be reused.

4.2.5

Unscrew the screw (17) from the housing (1) with **SPIDER SCREWDRIVER**.

4.2.6

Remove the front cover (7) from the housing (1).

4.2.7

Remove the diaphragm (6) from the housing (1).

4.2.8

Loosen and remove the inlet nipple (16) with **19MM HEX SOCKET** from housing(1). Use a **ADJUST TOOL** to turn left the orifice (16x) until remove it. Remove and discard all o-ring (15,16X-O) from inlet nipple and orifice.

4.2.9

Before remove the poppet (13) must be check and record the poppet thread length that over the nut screw(11). Use the **6MM COMBINATION WRENCH** hold the nut screw (11) and use the **4H POPPET TOOL** to turn left the poppet (13) until remove it. The spring (12), lever arm (9), thick washer spacer (10), thin washer spacer (8) and nut screw will fall when the poppet(13) removed. Remove the lp seat (13X) from the poppet (13).

4.3 CLEANING AND INSPECTION OF THE 2nd STAGE

4.3.1

Rinse all plastic and silicone parts in fresh warm soapy water solution. Rinse with clean warm water and then blow the parts dry with compressed air to remove any sand and dust particles.



! WARNING !

DO NOT use vinegar or other acid solutions on the plastic parts since this will cause the plastic to become brittle!

4.3.2

If necessary because of deposits or corrosion, clean all metal parts of the second stage in an ultrasonic cleaner or cleaning solution. See Section 5.3 for recommendations on cleaning solutions.

4.3.3

Inspect the housing (1) for any cracks or nicks. Look particularly closely at the area where the exhaust valve (4) seals and where the o-ring (15) place. Replace the housing if any cracks are found.

4.3.4

Inspect the sealing surface on the orifice (16X) (where the seating seal (13X) seals) for any nicks or scratches. Replace the orifice (16X) if any serious defects are found at the sealing area, or if the threads appear worn out.

4.3.5

Blow all dust and debris out of the orifice with clean compressed air.

4.3.6

Inspect the exhaust valve (4). Look carefully at the base of the barbed nipple where it comes out of the middle of the valve. Look for any tearing at this point. Replace the valve if any tears are found. Replace the valve if nicks or tears are found at the sealing edges of the valve.

4.3.7

During an Annual Overhaul, all parts included in the Annual Service Kit are replaced no matter what the condition of those parts. Carefully examine all other parts of the second stage for signs of deterioration. Replace those parts too where necessary

4.4 PRELIMINARY ASSEMBLY OF THE SECOND STAGE

4.4.1

Ensure that all parts are clean. To determine the identity of each O-ring in the Second Stage Service Kit, remove them from the bag and use the O-ring Identification Chart on the back page of this section. Lay each

O-ring over its corresponding picture on the page and read the description. Before installing new O-rings into the regulator, lightly lubricate the O-rings with Dow-Corning 111 Silicone Grease or LTI Christo-Lube 111[®].

4.4.2

Install the exhaust valve (4) into the housing by inserting the nipple into the square hole from the outside of the body. Reach inside the case and pull the nipple firmly with the fingers until you hear or feel it “click” into place. Inspect the exhaust valve to see that it is properly seated. Take care not to get any lubricating grease on the exhaust valve during this procedure.

4.4.3

Insert the new lip seat (13X) into the white poppet (13). Install the spring (12) onto the poppet. Insert the poppet assembly you have just assembled, into the housing (1).

4.4.4

Use the **4H POPPET TOOL to push the poppet(13). Install the thin washer (8) first, and then the thick washer (10). Hand tight the nut screw (11) to the poppet. Push poppet tool more power and insert the lever arm (9) between the thin washer (8) and the thick washer (10) (refer to the draw).**

4.4.5.

Use the **6MM COMBINATION WRENCH hold the nut screw and use the **poppet tool** turn right the poppet until the poppet thread length same the record.**

4.4.6

Install the new lubricated O-ring (16X-O) onto the orifice (16X). Screw the orifice into the inlet nipple (16) with the **ADJUST TOOL and turn right the orifice until the cone surface align the flat of inlet nipple.**

4.4.7

Install the new lubricated O-ring (15) onto the inlet nipple (16).

4.4.8

Screw the inlet nipple assembly to the housing (1).

4.4.9

Use the **19MM HEX SOCKET** to tighten inlet nipple to 85-95 in/lbs (9.6-10.7 Nm).

4.4.10

Adjust the orifice (16x) with the **ADJUST TOOL**. It is important that the final adjustment leaves the lever with about 1/8" (3.2 mm) free movement at the end, to allow for the natural wear of the lp seat (13X) during the use of the regulator. Adjust the orifice (16X) in, while moving the end of the lever up and down with the tip of your finger. When the orifice is too far out you will feel a firm springiness with no free movement. When the seat is too far in you will feel a great deal of looseness at the end of the lever. You want the orifice (16X) to be positioned so that you feel the 1/8" (3.2 mm) free play when you move the tip of the lever with your finger.

4.4.11

Install the exhaust tee (5) onto the body.

4.4.12

Install the diaphragm (6) into the housing (1) so that it sits evenly on the ledge. Install the front cover (7) over the diaphragm. The front cover (7) is the best tool to align the diaphragm into the body. Screw the four screws (17) assembly into housing.

4.5 SET- UP OF THE SECOND STAGE

4.5.1

Keep the adjust tool to inlet nipple.

4.5.2

Install the hose between a serviced first stage and the second stage, tighten snugly. Use wrenches to tighten the second stage hose connection.

NEVER tighten the hose with more than 40 in. lbs. (4.5 Nm) of torque. The inlet hose fitting can be weakened by over tightening.

Note: Attach the second stage to the overhauled and properly adjusted first stage that it is going to be used with, mounted on an air tank filled to the maximum pressure the regulator is going to be used with. Install an intermediate pressure gauge into one of the low-pressure ports.

4.5.3

Carefully turn the air on. There should be no air leaking from the second stage with proper intermediate pressure applied to the hose. Adjust the **ADJUST TOOL** turn left to feel a little leaking and then turn right the orifice until leaking just stop and then turn more 1/8 coil.

The best test to check for the slightest leaks is to immerse the second stage (with no cover or diaphragm installed) under pressure in water and look for bubbles indicating a leak. Unscrew the four screws (17) and the front cover (7) and the diaphragm (6) from the housing (1). Push the lever arm 2 or 3 times. Put the second stage in water and correct the problem if leaks are found. See Troubleshooting section 5.1 for help. Assembly the cover ring assembly and diaphragm again see section 4.4.12.

4.5.4

Work the lever up and down a few times while the regulator is pressurized. Each time the lever is released, no air hissing should be heard.

4.5.5

Turn the air off and release all air of regulator set. Loosed and remove the **ADJUST TOOL**.

5.0 HELPFUL HINTS

5.1 TROUBLESHOOTING

POSSIBLE CAUSE	RECOMMENDED ACTION
Inlet filter clogged.	Replace the filter.
Air supply to 1st stage insufficient.	Verify the supply air pressure. Make sure the customer had the air valve turned all the way on during the dive.
2nd stage improperly adjusted.	Refer to sections 4.5 and of this manual.

A. HIGH INHALATION EFFORT AT SURFACE (cracking effort in air):

POSSIBLE CAUSE	RECOMMENDED ACTION
2nd Stage adjusted improperly	Refer to sections 4.5 of this manual.
2nd stage spring force on high end of range	The spring (12) can be conditioned to a lower thrust. Use the 6MM COMBINATION WRENCH hold the nut screw and use the poppet tool turn right or left the poppet until the poppet thread length same the record . Run the sections 4.5 of this manual.

B. CREEPING INTERMEDIATE PRESSURE:

POSSIBLE CAUSE	RECOMMENDED ACTION
Damaged or worn 1st stage	Replace 1st stage

C. HISSING FROM SECOND STAGE (but intermediate pressure is OK):

POSSIBLE CAUSE	RECOMMENDED ACTION
Damaged or worn 2nd stage Ip seat (13x)	Replace Ip seat
Nicked orifice (16x) sealing surfaces	Replace orifice
2nd stage demand lever (9) bent too high	Replace lever
Worn O-ring (16X-O) on orifice (16X)	Replace O-ring
Worn O-ring groove on orifice (16X)	Replace orifice
Orifice (16X) out of adjustment	Adjust orifice

D. WET BREATHING:

POSSIBLE CAUSE	RECOMMENDED ACTION
Diaphragm improperly installed or hole in diaphragm	Check position of diaphragm visually. Replace if holes found by holding up to a light.
Damaged or loose fitting exhaust valve	Replace exhaust valve (4)
Crack in housing (1)	Replace housing
Worn O-rings (15)	Replace O-rings (15)
Scratched or worn inlet nipple (16) sealing surfaces	Replace inlet nipple (16)
Scratched or worn housing (1) sealing surfaces	Replace housing
Improper clearing techniques by diver	Instruct diver on clearing techniques
Extremely slow breathing allowing water to build up in housing rather than being blown out	Explain this result of slow breathing to diver.

E. HIGH FREQUENCY HUMMING OR BUZZING DURING INHALATION:

POSSIBLE CAUSE	RECOMMENDED ACTION
Harmonic resonance between the springs and other 1st stage components.	Change the 1st stage

F. LOW FREQUENCY FLUTTERING DURING INHALATION (Above the surface only):

POSSIBLE CAUSE	RECOMMENDED ACTION
Harmonic resonance between the springs and other 2nd stage components.	Remove, rotate and re-install diaphragm or switch diaphragm with another.
	Replace seating lip seat (13x)
	Remove, rotate and re-install spring (12)
	Explain to the customer that this is not harmful to the regulator, and does not happen underwater.

5.2 PARTS CLEANING RECOMMENDATIONS

5.2.1

Regulators that see heavy use, particularly those used in salt water, often require extra effort to remove dirt and corrosion from the parts of the regulator. Some suggested cleaning solutions are listed at the end of this section, and there are probably many others being used successfully. The following are a few general suggestions we can make.

5.2 PARTS CLEANING RECOMMENDATIONS

5.2.1

Regulators that see heavy use, particularly those used in salt water,

often require extra effort to remove dirt and corrosion from the parts of the regulator. Some suggested cleaning solutions are listed at the end of this section, and there are probably many others being used successfully. The following are a few general suggestions we can make.

5.2.2

Don't expect your cleaning solution to do all the work in a matter of seconds. If the solution cleans extremely rapidly, it is probably too strong and is etching the finish on the parts. Use a wooden or plastic stick or a soft bristle brush to help get rid of the thickest deposits. Take special care not to damage orifice sealing areas.

5.2.3

Soft parts absorb ultrasonic energy. Remove all O-rings and seals from metal parts before cleaning them. If possible, do not clean plastic parts with the metal parts, or at least understand that every plastic part you put into the ultrasonic cleaner is slowing down the ultrasonic cleaning process for the rest of the parts.

5.3 COMMONLY USED CLEANING SOLUTIONS

SOLUTION	COMMENTS
Hot Soapy water	Preferable. Good for plastic, silicone and plated metal parts.
Vinegar and water (equal part solution) (weaker solution in Ultrasonic Cleaner)	Ingredients easily available. Approx. 15 min. cleaning time. May damage chrome finish. Never use on plastic parts. Vinegar dissolves the plastics in most polymers making them brittle and more prone to breakage.
Simple Green R and Water	Simple Green is a readily available degreaser. Read the product label for mixing ratios with water.
Cleaning solutions recommended by ultrasonic cleaner manufacturers	The preferred choice. Check with the manufacturer for strengths and recommended uses for their cleaners. Choose soap solutions over acidic ones.

5.4 HANDLING TIPS

How your customers treat their regulators will directly influence the unit's function and durability.

Following are a few tips that you can pass on to your customers to help assure the durability of their **SCUBAMAX** Scuba Regulator.

A. PRE-DIVE CHECKS:

5.4.1

Check the hoses and hose connections for cuts, abrasions or other signs of damage before mounting the regulator on the tank valve. Slide the hose protectors back to inspect the areas of the hose normally covered. Be sure all hose connections are tight.

5.4.2

Just before mounting the regulator on the valve , always turn the valve on

briefly to blow any trapped water out of the valve . There is often salty water trapped in the outlet side of the valve . This entrapped salt water being blown through the interior of the regulator is the number one source of internal corrosion and problems with Scuba regulators.

5.4.3

Before turning on the tank air valve , check to make sure that the yoke nut or DIN connection is tight and the regulator body is aligned properly , with no kinks in the hoses.

5.4.4

Turn the tank valve on slowly and listen for leaks. If any leaks are found, replace or repair parts as recommended.

5.4.5

Never lift the tank/BCD assembly by the regulator or hoses.

5.4.6

Surface-test the regulator by breathing lightly through the mouthpiece . Depressing the purge button above the water's surface is not an effective or thorough method for testing the function of the regulator.

B.POST-DIVE CARE:

5.4.7

After the dive, blow all water out of the dust cap with clean dry air or dab the water out with an absorbent cloth and place the cap securely on the regulator inlet. On multiple tank dives, use great care to keep salt water out of the regulator inlet when tanks are changed. Neglecting these simple procedures is another great cause of corrosion and wear in Scuba regulators.

5.4.8

With the dust cap securely in place, rinse the first and second stages in clean fresh water. DO NOT depress the purge button before or during rinsing since this may introduce water into the second stage and the low-pressure hose. Shake or blow all excess water from the second stage and allow the entire regulator to air-dry before storing.

5.4.9

Store regulator in a clean bag or storage box , away from sunlight , excessive heat and humidity.